

est.  2011

JTP | JOINERY

Window & Door Specialists

ENHANCING HOMES  
*with* **HANDCRAFTED**  
TIMBER WINDOWS  
& DOORS



# ABOUT JTP JOINERY

With extensive experience within the industry, our expert teams have been manufacturing, installing, and refurbishing all manner of timber windows and doors throughout Devon, since our incorporation in January 2011.

Our well-equipped production facility utilises state of the art machinery alongside highly skilled craftsmen, giving us the ability to produce all styles of joinery; from period and historical to architectural and modern designs including Passivhaus commissions.



SEE OUR 5 STAR GOOGLE  
REVIEWS ONLINE BY  
SEARCHING JTP JOINERY  
OR SCAN QR CODE



# Contents

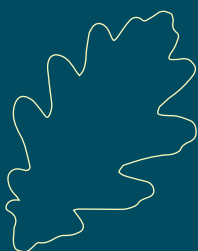

Choosing Timber for Your Project	04.
Frequently Asked Questions	05.
Accoya Wood	06.
Tested & Approved	08.
Conservation Range Windows	12.
Heritage Range Windows	14.
Bespoke Range Windows	16.
Sliding Sash Windows	18.
Entrance Doors	22.
External Doors	24.
Heritage Double Doors	26.
Bi-Fold Doors	28.
Sliding Doors	29.
Sash Window Restoration	30.
Double Glazing Existing Windows	32.
Ironmongery	36.
Glass Options	38.
Manufacturing	40.

## CHOOSING TIMBER FOR YOUR PROJECT

Investing in timber windows and doors offers a myriad of compelling reasons that go beyond just their aesthetic appeal.

Not only are our windows and doors eco-friendly and sustainable, but they also offer timeless charm and durability. Their excellent insulating properties help to reduce energy costs, and our craftsmanship creates unique and elegant designs.

Customisable to fit any size and style, our timber products provide endless possibilities for personalised aesthetics.

With natural resilience against various weather conditions, timber ensures long-lasting performance and timeless charm. With a life expectancy in excess of 50 years, when compared to that of 20 years for UPVC products, the renewable recourse of timber is becoming ever more popular amongst discerning homeowners.

Moreover, our timber windows and doors infuse spaces with a warm and inviting ambiance, bringing the beauty of nature indoors. Embrace the allure of timber windows and doors for a harmonious blend of elegance and practicality.



# FAQ's

## Where are the windows/sashes made?

All of our windows are manufactured in our Newton Abbot workshop by our time served craftsmen to each individual specification.

## I am within a conservation area/listed building can you help?

Our surveyors have extensive experience in dealing with local authorities and are well equipped to advise you of the restrictions and advise of the best course of action for your windows. Our surveyor will assist and guide you through the application should Listed Building Consent be required for replacement windows or double glazing. In most cases we can overhaul windows and install our perimeter draught seal system without the requirement for any form of consent.

## Can works be carried out during the winter months?

All of our services are carried out year-round with every care taken to minimise disruption to your home. During the winter months our teams set up gazabo's to shelter from the rain and protect the windows as required.

## How disruptive will the works be?

We always aim to keep disruption to a very minimum to ensure the process is as enjoyable and hassle free as possible. Our installers will always cover all furniture within each room and also apply carpet protector throughout all walkways and working areas. All power tools use portable dust extraction, and our team will always hoover up at the end of each day. As with any home improvement works being carried out an element of disruption and dust is inevitable however, we aim to leave your home as clean and tidy as it was when we arrived.

## Do you offer services which cover the replacement or refurbishments of other types of windows and doors?

We have a wide range of services available including the manufacture, installation and refurbishment of all types of timber windows and doors including casement windows, stable doors, french doors and bi folding doors.



## What are the benefits of the perimeter draught seal system?

There are several benefits of the perimeter draught seal system with the most notable benefits being the vast improvement in heat loss, the elimination of rattles, the improvement of sound insulation and the reduction in dirt ingress. Another benefit is the very noticeable difference in how the window operates. With the sashes running on back to back brush seals they will glide effortlessly within the box frame.

## Should I be replacing timber windows?

This is something that will be discussed by our surveyor during the initial site visit. If your windows are repairable then we would always opt for one of our overhauling, draught proofing or double glazing options as these will cause far less disruption to your home whilst also saving a considerable amount of money.

## Do you carry out works for commercial clients?

We can manufacture, install and refurbish windows for commercial clients, of course. We have built up an enviable reputation locally with many contractors and developers. All of our site teams hold current CSCS cards along with other relevant H&S certification such as Asbestos Awareness and First Aid. As a company we are SMAS accredited. Please see our Commercial and professional page for more information.

## Can I get free advice and a free of charge quotation?

All of our quotations are free of charge and come with no obligation to buy our products or services. Our surveyors will always give you honest advice and advise of the most cost effective service to suit your individual needs.

Accoya turns everything you know about wood on its head. Through a revolutionary scientific process called acetylation, it modifies wood to give it properties that exceed hardwoods, and other materials such as PVC and aluminium.



## HERE ARE SOME OF THE BENEFITS OF ACCOYA FOR YOUR WINDOWS AND DOORS:

### Performance

Accoya windows and doors are highly stable and durable. They do not shrink, swell or distort and will open effortlessly all year round. Naturally insulating, and a 40% thermal conductivity improvement over hardwood, they'll help keep your home cosy and your energy bills down. A 50 year warranty also means you'll get to enjoy your windows or doors for a lifetime.



50 YEAR WOOD WARRANTY



VERY LOW MAINTENANCE



NATURALLY INSULATING

### Finish

Accoya is the perfect material for coatings. Because of Accoya's amazing stability, coatings last longer than on other wood species, meaning lower maintenance in years to come.



NATURAL WOOD



IDEAL FOR COATINGS



BESPOKE OPTIONS

### Sustainability

Accoya is a natural wood product sourced from sustainably managed FSC® certified forests. With no plastic, resin or other harmful additives Accoya is 100% non toxic, making it the ideal environmental choice.



NON TOXIC



CARBON NEGATIVE OVER LIFE CYCLE



SUSTAINABLY SOURCED

## The Accoya Advantage:

- Reduced swelling and risk of jamming in humid conditions
- Better fitting windows and doors in all weathers
- Less frequent coatings maintenance
- Joinery that will stand the test of time and not require replacement for at least 50 years
- Ideal for exposed / coastal applications
- Beauty, elegance and style – natural or coated



SCAN FOR  
MORE INFO



# TESTED & APPROVED

Ensuring that windows and doors are compliant with building regulations is of utmost importance for any homeowner or builder. Not only does it guarantee the safety and security of occupants, but it also plays a vital role in energy efficiency and environmental impact. Building regulations are designed to establish standards for structural integrity, ventilation and access, all critical aspects of a well-constructed property. By adhering to these regulations, you can be confident that your windows and doors meet the highest industry standards, providing peace of mind and safeguarding your investment.

Don't compromise on safety or sustainability—choose windows and doors that meet building regulations to create a comfortable, secure, and environmentally responsible living space for years to come.



The JTP Joinery Conservation range of timber windows and doors is characterised by slim sight lines, elegant profiles, and high performance. From flush casement and sash windows to French, bi-fold and entrance doors, this suited range offers styling to suit both traditional and modern properties.



**Our Conservation range meets and exceeds all current UK Building regulations and British standards including**

**PAS24  
2016**  
FOR SECURITY

**DOCUMENT  
PART Q**  
FOR SECURITY

**BS 6375:1**  
FOR WEATHER  
PERFORMANCE

**DOCUMENT  
LB1**  
FOR ENERGY  
EFFICIENCY

**DOCUMENT  
PART M**  
FOR ACCESSIBILITY

**SO YOU CAN COMPLY WITH BUILDING REGULATIONS**





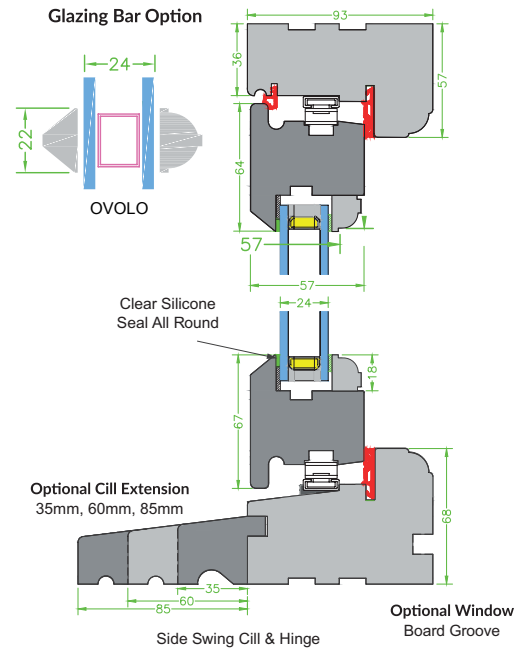

# CONSERVATION RANGE

**High-performance timber window for conservation and beyond**

- Fully compliant with modern building regulations (Part Q, thermal/weather, security)
- Multipoint locking, 24mm DGU
- Suitable for conservation areas as well as new build
- Ideal for clients wanting traditional aesthetics with modern performance



SCAN FOR MORE INFO



**PAS24:2016 FOR SECURITY**

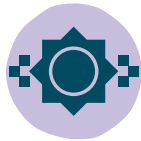

**SECURED BY DESIGN SYSTEM**



**DOCUMENT Q COMPLIANT**



**DOCUMENT L COMPLIANT**



**DOCUMENT M COMPLIANT**



**BS6375-1 2009 WEATHER TIGHTNESS**



**DOUBLE OR TRIPLE GLAZING**

## SPECIFICATION

<b>Frame Options</b>	93mm x 57mm Jamb 93mm x 68mm Head & Cill 93mm x 68mm Transom & Mullion 93mm x 68mm Flying Mullion when required
<b>Casement</b>	64 x 57mm Top Rail & Stiles 67 x 57mm Bottom Rail 22mm – Glazing Bar
<b>Sash Profile</b>	Ovolo
<b>Cill Projection</b>	35mm, 50mm, 70mm, 90mm
<b>Glazing</b>	24mm Low E Sealed Unit (4mm/16mm/4mm) with Argon gas  Black Warm Edge Spacer Options - Obscure, Sound Control, Toughened & Laminated, Security Bead & Clip glazing system

## HARDWARE / FITTINGS

<b>Hardware</b>	Friction hinges for side and top swing Sashes with Multipoint locking system.
<b>Handles</b>	See Ironmongery brochure for vast range in assorted finishes.
<b>Trickle Vents</b>	Surface mounted internal vent and external canopy 4600EA

## TEST DATA

<b>BS6375 Part 1</b>	Air Permeability Class 4, Water tightness Class 4 Resistance To Wind Load Class C5
<b>Acoustic Rating</b>	RW(C;Ctr) = 36 (-2,6) db (With Sound Control Glass)
<b>Thermal Rating</b>	1.3 W/m <sup>2</sup> K (with double glazing) WER A or A+
<b>Security</b>	PAS 24 and Secured by Design where required





## Glazing Options:

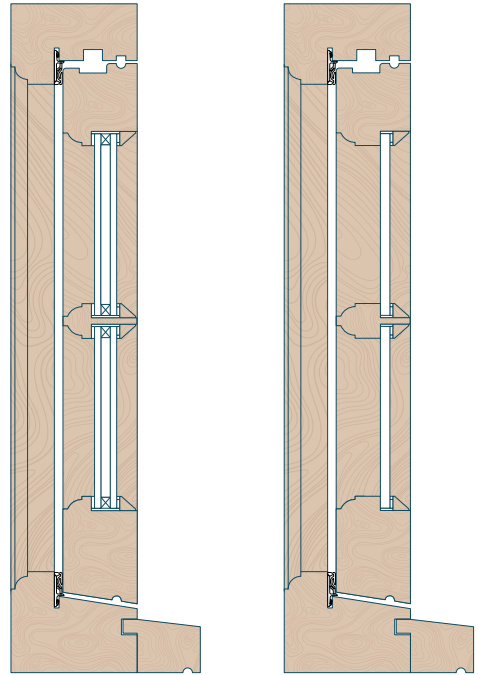

1 Double Glazed (16mm)

2 Single Glazed (3mm - 11mm)

*Vacuum Glazing also available in this design*

## HERITAGE RANGE

### Authentic heritage detailing with modern performance options

- Traditional or high security ironmongery options
- Slimline DGUs or putty-glazed options with true glazing bars
- Suitable for conservation areas and many listed buildings (subject to approval)
- Aesthetic authenticity with upgraded security

The Heritage Casement Window from our Classic Range is a beautifully crafted, flush-faced timber window that seamlessly blends timeless design with exceptional performance. Whether your property is period, traditional, or bespoke, this window style is designed to complement and enhance a wide range of architectural eras.

Custom-made to your exact specifications, our Heritage Casement Window features 16mm slimline double-glazed units, optional traditional putty-faced detailing, and true glazing bars for an authentic heritage appearance. Engineered for superior thermal insulation, acoustic comfort, and lasting aesthetic appeal, this window brings charm and efficiency together in perfect harmony.

### Key Information:

- Can be double (16mm) or single glazed
- Traditional Ovolo, Lamb's Tongue, Angled or Square Moulding options for frame and casement internally
- Lift Off Hinges
- Multi-point lock
- Friction arm to hold the casement in any open position

## Design Examples

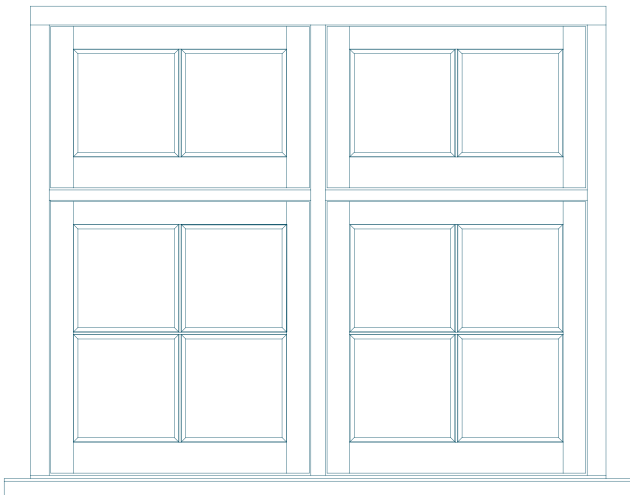

Twin Casement with Fan Lights and Mullion



Single Casement

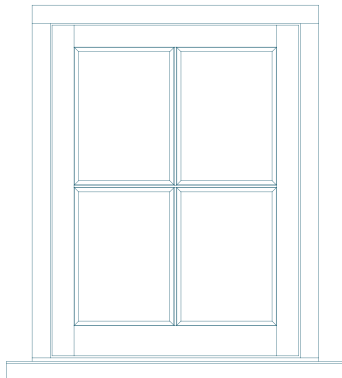

High-performance multi-point locking systems provide superior security and reliable operation in all weather conditions.



Slim-profile sections preserve the refined look of traditional timber windows while maintaining structural integrity.



Traditional-style lift-off hinges offer authentic exterior aesthetics with easy access for installation and cleaning.





## BESPOKE RANGE

**Tailored joinery for sensitive historic and listed buildings**

- Built to match original details more precisely for LBC compliance
- Handcrafted to replicate profiles, mouldings, glazing styles
- Ideal for buildings under stricter planning constraints i.e. Listed buildings & National parks



*Images of Timber replacement and refurbishment works carried out by our skilled craftsmen*





SCAN FOR MORE INFO

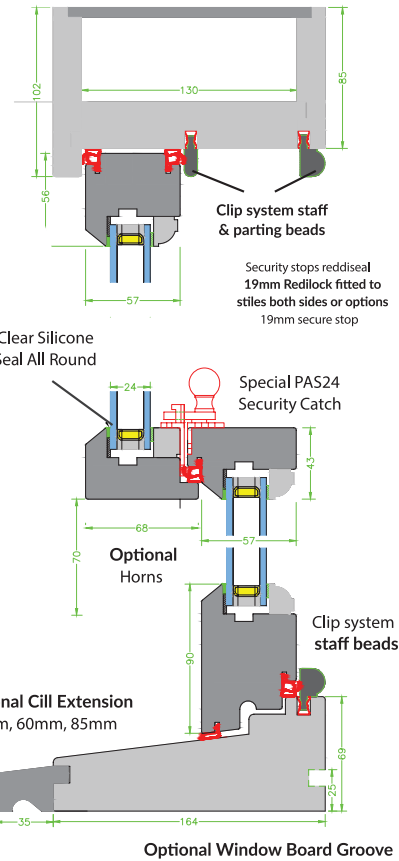

## CONSERVATION RANGE HERITAGE BOX SASH WINDOW

Traditional box sash windows are the enduring design of grand Georgian houses, Victorian villas and elegant Edwardian homes.

Box Sash Windows offer an authentic conservation replacement to retain the traditional features of a period property renovation.

The window provides excellent energy efficiency and security performance, making it an ideal choice for both refurbishment and new build projects.



**PAS24:2016  
FOR SECURITY**



**1.3W/M2K  
U-VALUE**



**DOCUMENT Q  
COMPLIANT**



**DOCUMENT L  
COMPLIANT**



**DOCUMENT M  
COMPLIANT**



**BS6375-1 2009  
WEATHER  
TIGHTNESS**



**DOUBLE OR  
TRIPLE  
GLAZING**

### SPECIFICATION

<b>Frame Options</b>	102mm x 164mm Head & Jambs 164mm x 68mm Cill
<b>Sash</b>	56 x 57mm Top Rail & Stiles 90mm x 57mm Bottom Rail 47 x 57mm Meeting Rail 22mm – Glazing Bar
<b>Sash Profile</b>	Ovolo
<b>Cill Projection</b>	35mm, 50mm, 70mm, 90mm
<b>Glazing</b>	24mm Low E Sealed Unit (4mm/16mm/4mm) with Argon gas  Black Warm Edge Spacer Options - Obscure, Sound Control, Toughened & Laminated, Security Bead & Clip glazing system

### HARDWARE / FITTINGS

<b>Hardware</b>	Sash catch, Sash Lifts x 2 Restrictors if required
<b>Trickle Vent</b>	Surface mounted internal vent and external canopy 4600EA

### TEST DATA

<b>BS6375 Part 1</b>	Air Permeability Class 3, Water tightness Class 8A to 450PA Resistance To Wind Load Class C5
<b>Acoustic Rating</b>	RW(C;Ctr) = 36 (-2,6) db (With Sound Control Glass)
<b>Thermal Rating</b>	1.3 W/m <sup>2</sup> K (with double glazing)
<b>Security</b>	PAS 24 and Secured by Design where required



# CASE STUDY: TEIGNMOUTH

*Casement Windows, Sash Windows,  
Replacement Sashes in to existing box  
frames, French Doors and Entrance Doors.*

**Exuding elegance and style after an extensive renovation, these premium apartments in Teignmouth really have the WOW factor! Featuring a combination of our products and services; sash window refurbishments, new sash windows, new casement windows, new entrance door and French doors.**

Carried out over two phases, the first consisting of nine complete new sash windows and eight casements windows, two French door sets and one entrance door.

It was important for the developer to install timber windows and doors with a traditional

appearance. Choosing an anthracite spray finish and satin chrome hardware to perfectly compliment the aesthetics of the property.

The second phase consisting of four windows having new sashes into their existing box frames and three complete new sash windows. All products were manufactured and installed by us and benefit from multi-point locking systems and draught seal solutions.

By choosing Accoya over other timbers, the developer is ensuring stability and durability for many years to come in this coastal location, with minimal maintenance required.





**Stepping through the robust Accoya entrance door into each apartment, our spectacular windows perfectly frame the view out across the South Devon coastline.**



SCAN FOR MORE INFO

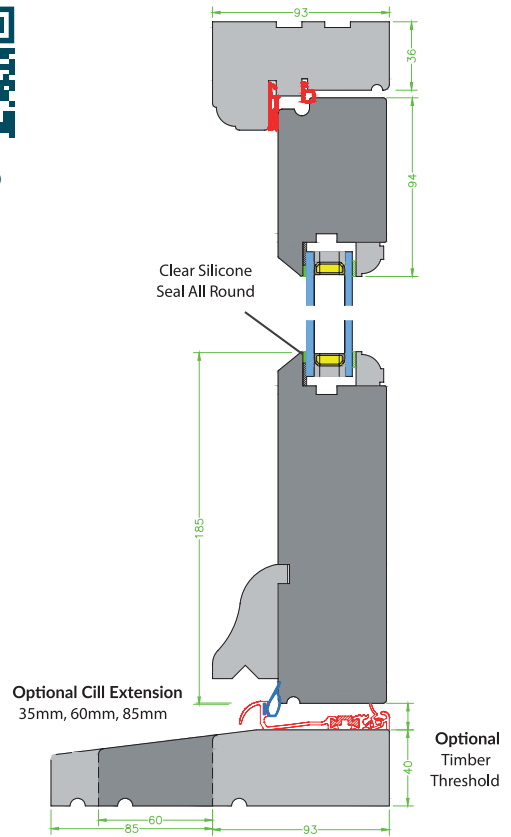

## CONSERVATION RANGE

### HERITAGE SINGLE DOOR (OPEN IN)

Our timber entrance doors are available to open either outward or inwards.

The Document Q compliant door is energy efficient and features high security multi-point locking.

The flexible inward opening design is suitable for main entrance, side or rear doors. It allows for various glass and solid panel combinations. This makes it easy to produce almost any style of door.



**PAS24:2016 FOR SECURITY**



**SECURED BY DESIGN SYSTEM**



**DOCUMENT Q COMPLIANT**



**DOCUMENT L COMPLIANT**



**DOCUMENT M COMPLIANT**



**BS6375-1 2009 WEATHER TIGHTNESS**



**DOUBLE OR TRIPLE GLAZING**

#### SPECIFICATION

<b>Frame</b>	93mm x 57mm Jamb
<b>Options</b>	93mm x 68mm Head 93mm x 40mm Cill with Metal Storm guard Threshold 93mm x 68mm Transom & Mullion
<b>Sash</b>	94 x 57mm Top Rail & Stiles 160mm x 57mm Bottom & Mid Rail 22mm - Glazing Bar
<b>Sash Profile</b>	Ovolo
<b>Cill Projection</b>	35mm, 50mm, 70mm, 90mm
<b>Glazing</b>	24mm Low E Sealed Unit (4mm/16mm/4mm) with Argon gas  Black Warm Edge Spacer Options - Obscure, Sound Control, Toughened & Laminated, Security Bead & Clip glazing system

#### HARDWARE / FITTINGS

<b>Hardware</b>	Lift Off Radius Butt Hinges Multi-point Thunderbolt or Slam Shut lock Storm Guard Threshold Lever Handle <b>Options:</b> Knob/Pull handle with additional cylinder pull Letterplate
<b>Handles</b>	See Ironmongery brochure for vast range of all ironmongery in assorted finishes.
<b>Trickle Vent</b>	Surface mounted internal vent and external canopy 4600EA

#### TEST DATA

<b>BS6375 Part 1</b>	Air Permeability Class 2, Water tightness Class 3A Resistance To Wind Load Class 800X
<b>Acoustic Rating</b>	RW(C;Ctr) = 36 (-2,6) db (With Sound Control Glass)
<b>Thermal Rating</b>	1.4 W/m <sup>2</sup> K (with double glazing)
<b>Security</b>	PAS 24 and Secured by Design where required



4

4

YEALM

# EXTERNAL / BACK DOORS

Elevate your home with our bespoke wooden doors, where craftsmanship meets functionality.

Each door, meticulously crafted from premium timber, adds a touch of character and sophistication to your living spaces.

Our doors seamlessly connect indoors with the outdoors while enjoying enhanced energy efficiency and security for the utmost piece of mind. Choose from timeless designs or modern twists and experience the perfect balance of style and practicality. From stable doors to modern glazed models, our master craftsmen create every door to your specific requirements to ensure your doors reflect your individual style and the requirements of your family home.

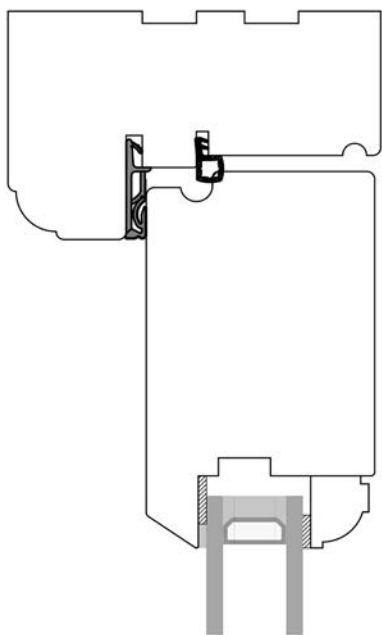





## CONSERVATION RANGE HERITAGE DOUBLE DOORS (OPEN OUT)

Our timber double doors are the classic French door set, available as either outward or inward opening.

This outward opening version offers flexible design options for traditional, contemporary or modern styling. The doors are suitable for a range of threshold options including mobility access.

The double doors are energy efficient and PAS 24:2016 certified for high security. The system is also Secured by Design.

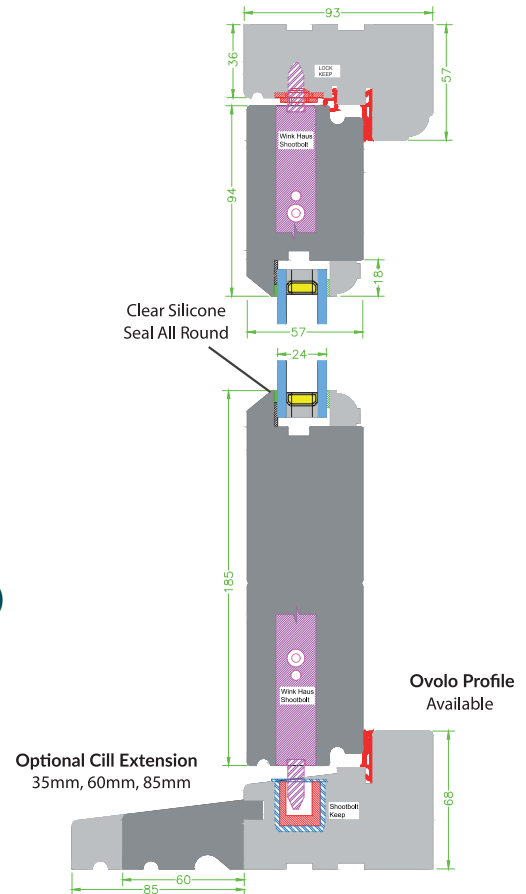

**PAS24:2016  
FOR SECURITY**



**SECURED BY  
DESIGN SYSTEM**



**DOCUMENT Q  
COMPLIANT**



**DOCUMENT L  
COMPLIANT**



**DOCUMENT M  
COMPLIANT**



**BS6375-1 2009  
WEATHER  
TIGHTNESS**



**DOUBLE OR  
TRIPLE  
GLAZING**

### SPECIFICATION

<b>Frame Options</b>	93mm x 57mm Jamb 93mm x 68mm Head 93mm x 68mm Cill 93mm x 68mm Transom & Mullion
<b>Door</b>	94 x 57mm Top Rail & Stiles 160mm x 57mm Bottom & Mid Rail Overall meeting stile width - 190mm 22mm - Glazing Bar
<b>Door Profile</b>	Ovolo
<b>Cill Projection</b>	35mm, 50mm, 70mm, 90mm
<b>Glazing</b>	24mm Low E Sealed Unit (4mm/16mm/4mm) with Argon gas  Black Warm Edge Spacer Options - Obscure, Sound Control, Toughened & Laminated, Security Bead & Clip glazing system

### HARDWARE / FITTINGS

<b>Hardware</b>	Lift Off Radius Butt Hinges Multi-point Thunderbolt Lever handle set on each door
<b>Handles</b>	See Ironmongery brochure for vast range of lever handles in assorted finishes.
<b>Trickle Vent</b>	Surface mounted internal vent and external canopy 4600EA

### TEST DATA

<b>BS6375 Part 1</b>	Air Permeability Class 2, Water tightness Class 3A Resistance To Wind Load Class 800X
<b>Acoustic Rating</b>	RW(C;Ctr) = 36 (-2,6) db (With Sound Control Glass)
<b>Thermal Rating</b>	1.4 W/m <sup>2</sup> K (with double glazing)
<b>Security</b>	PAS 24 and Secured by Design where required



# BI-FOLD DOORS

**Experience the seamless fusion of indoor and outdoor living with our exquisite range of timber bi-folding doors.**

Crafted from the finest materials and incorporating premium grade operating systems, our doors redefine versatility and elegance within your living space. Our timber bi-folding doors effortlessly connect your interiors to the surrounding environment, allowing for uninterrupted views and an abundance of natural light.

Each panel is a testament to our commitment to quality, offering smooth operation and robust security features.

Whether you're looking to expand your living area or create a captivating transition to the outdoors, our bi-folding doors are the perfect choice. Embrace the beauty of timber while enjoying modern functionality, and transform your home into a harmonious retreat that embraces the art of modern living, with a traditional embrace.

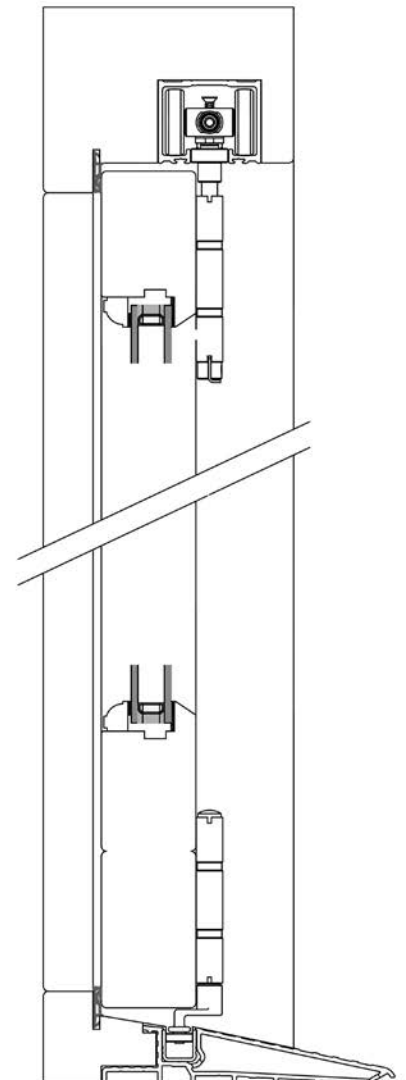



### OPTION A

2 SLIDING DOORS



### OPTION B

2 SLIDING DOORS & 1 FIXED OUTER DOOR

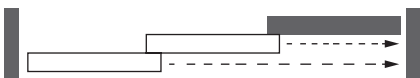

### OPTION C

4 SLIDING DOORS & 2 FIXED OUTER DOORS



## SLIDING DOORS

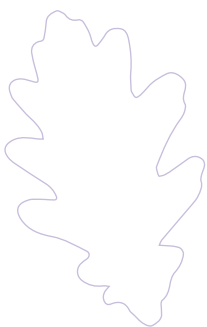

**Installing a wall of glazing incorporating fixed and sliding panels is sure to transform your living space, creating a fluid connection between your home's interior and the outdoor space.**

Each door set reflects our dedication to quality, combining smooth sliding mechanisms with robust security features. Whether you seek a minimalist design or a statement piece that enhances your

home's character, our timber sliding doors offer an elegant solution.

Embrace the essence of modern living and experience the beauty of timber in motion as you effortlessly slide your door open to the world beyond.

Your sliding doors can open from either side for effortless access to your garden and fluid indoor-outdoor living.

# SASH WINDOW RESTORATION



SCAN FOR MORE INFO

Traditional sash windows add beautiful charm and character to period properties however, over the years issues can develop which can make living with your sash windows less comfortable. Whether you're suffering with rattles and draughts, rotten frames, broken sash cords or cracked glazing, we are on hand to help. We can even double glaze your existing windows without replacing the box frame.



## Some of the most common sash window problems that we can help with

- ❁ Excessive condensation
- ❁ Cold and draughty windows
- ❁ Sashes that rattle in the wind
- ❁ Rotten or leaking frames and cills
- ❁ Sashes which have been painted shut
- ❁ Broken sash cords
- ❁ Sashes which drop when opened
- ❁ Cracked, scratched or misted glass
- ❁ Defective pulley wheels and locks

# SASH WINDOW OVERHAUL AND UPGRADE SERVICE

*The perfect solution for listed buildings*

As well as reducing heat loss, our overhaul and upgrade service will ensure that your windows glide effortlessly within the existing box frames. Outside noise pollution and dirt ingress will be reduced whilst sashes rattling in the wind will be a thing of the past.

Our English Heritage-approved perimeter draught seal system was specifically designed to bring traditional windows into the 21st century without compromising the traditional character and charm of the windows.

The discreet and aesthetically pleasing perimeter draught seal system can be installed into windows within a conservation area or listed building without the requirement for planning permission or listed building consent.

As part of your sash window overhaul the windows will also benefit from re-balancing with new sash chords, and replacement staff and parting beads to match the originals, this helps to improve the internal appearance of your windows. Replacement lockable sash fasteners and lifts will be installed as well as security restrictors where required.



# DOUBLE GLAZING YOUR EXISTING SASH WINDOWS

*The cost effective solution for conservation areas*



JTP Joinery made and fitted replacement sashes for several windows, plus repairs to some of the frames. Very pleased with the quality of the new windows, and the remarkably short time it took to make them. Jack and Herbie did a fine job on-site and left everything tidy. This is the second time they have done work for me, and I would happily recommend them.”

**Andrea Atkin**

It has long been thought that to have double glazed sash windows would mean replacing the entire window which can be costly and disruptive to your home, here at JTP Joinery we have an innovative solution to this.

We are able to manufacture replacement sashes (the moving parts) that fit within your existing box frames, replicating the finer details such as glazing bars and decorative horns. The new sashes will incorporate Slim line heritage double glazing to maintain the character and charm of your windows whilst vastly improving your heat retention.

Our slim line heritage double glazed units come with warm edge super spacer bars as standard, Argon gas and employ the latest Planitherm glass technology for maximum thermal efficiency.

Your replacement sashes can be manufactured from a range of timbers to suit all requirements and budgets from Scandinavian Redwood to Solid Hardwood although our recommended timber is usually Accoya.

All replacement sashes will have 2 coats of micro porous paint applied prior to installation.



SCAN FOR  
MORE INFO

Whilst installing replacement, double glazed sashes into the existing box frames, our installers will carry out all repairs to your existing frames as required. Alongside the replacement sashes our master craftsmen will install replacement lead weights to counterbalance the heavier glazing, replacement sash cords and ironmongery,

new staff and parting beads and also install our unique perimeter draught seal system.

The end result is an effortlessly sliding double glazed sash window, of traditional appearance which will perform as if it were brand new, with less disruption and cost than the complete replacement alternative.



**We are delighted with our new sash windows, the difference in warmth and sound is tremendous. The thought of removing the frames and disturbing the plaster was too much to bear at our age, replacing just the windows was perfect for us. The whole service was stress free, the fitters were polite, friendly, and helpful. We have already placed an order for a further 7 windows to the back of our house. Thank you to all at JTP Joinery”**





“

This was the fourth project in which we have employed JTP Joinery for sash window refurbishment and replacement works with 3 of these projects being within the Exeter area. Having worked with several of the national companies in the past, the benefits of using a local specialist are clear to see. The project management and H&S awareness have been excellent throughout each of the projects.”

**Contractor, Winslade Park**



# IRONMONGERY

**We are proud of our partnerships with local suppliers who bring together an extensive selection of architectural hardware and ironmongery.**

We can cater for all tastes and colour schemes with our hardware collection offering a wide range of options – from polished and antiques brass to black and polished or satin chrome.

If you are looking to add that finishing touch to your beautiful timber windows or doors, we have an option to suit all designs and colours – adding more than a practical accessory, these stunning pieces offer an exquisite, long lasting beauty in their own right to compliment our beautiful range of windows and doors.





# GLASS OPTIONS

Our range of timber windows and doors features a variety of glazing options designed to suit every requirement. We offer expert advice on the best solutions, considering both conservation needs and lifestyle preferences. Our aim is to deliver the perfect balance of aesthetics, energy efficiency, and sound insulation, ensuring your space stays comfortable and quiet.



For listed buildings, we offer a 4mm single-glazed pane or a slim 14mm double-glazed unit filled with krypton gas, available with a 22mm wide 'thru' glazing bar if required. These options provide an ideal solution for heritage properties.

If you're seeking an efficient yet affordable choice, our high-performance 24mm double-glazed units filled with argon gas offer excellent thermal regulation without a high price tag.



For those looking for the ultimate in energy efficiency, we recommend vacuum-sealed units. At just 10mm thick, these units provide over twice the insulation performance of 24mm units and come with a 20-year guarantee. Though they carry a premium price, their long-term benefits make them an outstanding investment.

---

**Contact our team for more information or to see samples in person.**

# DECORATIVE GLASS

We have a large range of decorative glass options available including stained and leaded units as well as many obscure and etched glass designs. – Request to see our Fittings and finishing touches brochure for more information.



# MANUFACTURING

Our renowned timber window and door manufacturing facility is a testament to craftsmanship and excellence since its inception in 2011. Nestled in the heart of our community, our workshop stands as a haven for artisanal woodworking dedicated to the creation of exquisite timber windows. For over a decade, our skilled craftsmen have been blending traditional techniques with modern innovations to produce windows and doors that seamlessly merge timeless elegance with contemporary functionality.

The workshop is a symphony of creativity and precision, where each piece of wood is meticulously hand picked for its character and quality, and every intricate detail is carved with unwavering dedication. From the rhythmic hum of saws to the earthy aroma of freshly cut wood, stepping into our workshop is a sensory experience that transports you to a world where craftsmanship is paramount. With every window that leaves our workshop, we carry forward the legacy of excellence that has defined us since day one.



SCAN FOR  
MORE INFO

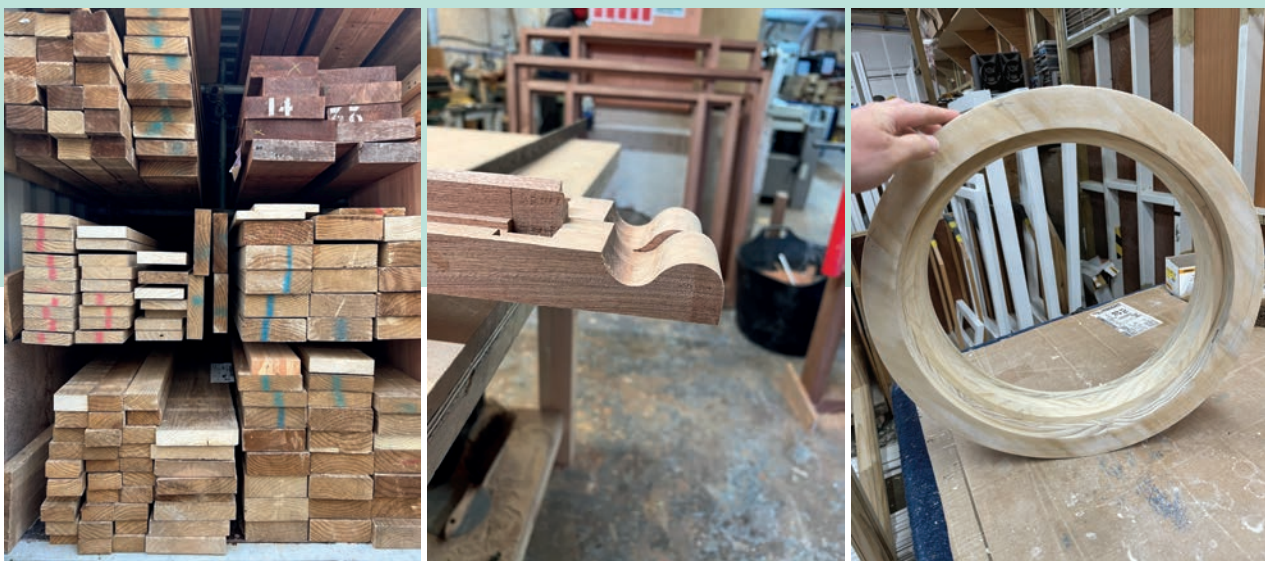

Having an in-house CAD draughtsman enables us to produce detailed drawings for our clients prior to manufacture. Our CAD draughtsman and design team ensure that each and every product is manufactured to our clients exacting specifications.



**In late 2018 we acquired the neighbouring premises and expanded our spray room and glazing facilities to further meet demand and accelerate production.**

**From this growth we are now able to deliver even more high quality products and services.**

## Basic Installation Specification

*Our BASIC installation process will include all of the following:*

- Removal of the existing window/door set. During this process there may be damage to the reveals/openings from which the existing windows are being removed. This will be kept minimal and discussed with the customer if seen to be excessive.
- Disposal of the existing windows/door sets unless otherwise agreed in writing with Phil or Tom.
- The new products will be installed with the best possible care and attention in order to protect the new products.
- All opening casements, sashes and doors should work without the customer having to use excessive force. If excessive force is required, please consult the installer before the installation is complete.
- All products will be secure and draught proof once installed. The windows will not be completely weather tight until the 'making good' has been completed by a suitable trades-person.
- If a lintel above a window is deemed unsafe it will need to be repaired by a builder before the new window is installed. This unfortunately cannot be included in JTP Joinery's installation price.



## Comprehensive Installation specification

*Our COMPREHENSIVE installation process will include all of the following:*

- Removal of the existing window/door set. During this process there may be damage to the reveals/openings from which the existing windows are being removed. This will be kept minimal and discussed with the customer if seen to be excessive.
  - Repairs to any damaged reveals/openings from which the windows have been removed including internal window boards.
  - Where painting of reveals is required the customer will need to provide a suitable paint to do so.
  - External 'Sub Cills' i.e slate or concrete Cills will not be repaired or painted unless agreed in the final quotation or in writing with Phil or Tom.
  - Disposal of the existing windows/door sets unless otherwise agreed in writing with Phil or Tom.
  - The new products will be installed with the best possible care and attention in order to protect the new products. If 'touch ups' are required they will be undertaken by the installers.
  - All opening casements, sashes and doors should work without the customer having to use excessive force. If excessive force is required, please consult the installer before the installation is complete.
  - All products will be secure and draught proof once installed. The windows will become completely weather tight once the making good is complete.
  - If a lintel above a window is deemed unsafe it will need to be repaired by a builder before the new window is installed. This unfortunately
- 

# TESTIMONIALS

## TORQUAY

Entrance Doors, French Doors,  
Sash Windows, Casement Windows.



*Our whole experience with JTP Joinery from the first point of contact to the very end was nothing but professional. Extremely good customer service and very high quality work. The fitters, Chris and Aaron, were extremely professional and incredibly clean and tidy. Tayler and Phil kept us updated throughout the project and answered any queries promptly. At the end of the job the work was quality assured by Tayler. We will definitely be using JTP Joinery again. Highly recommended”.*

## NEWTON ABBOT

Casement Windows, French Doors, Sun Room



“

*The windows and doors arrived promptly on site as promised and the fitting and installation was first class, with excellent attention to detail and a tidy finish. Delighted with our new windows and door and would not hesitate to ask JTP to complete any further work we require in the future.”*

## SOUTH HAMS

Conservation Area - Casement Windows, Doors, Sash Windows



*JTP Joinery have carried out various projects on our period property in the South Hams over 18 months. Works completed include sash windows, casement windows and beautiful doors. JTP took care of everything including the fitting and painting. Phil was always on hand to visit site as required and the whole team were very accommodating. Dealing with JTP has been professional and enjoyable. We have already recommended to friends.”*



## Teignmouth

Replacement High performance Windows and Doors



## Stoke Gabriel

Replacement Accoya Sash Windows and Doors



## Torbay

Replacement  
Entrance Doors  
& French Doors

# COMMERCIAL



SCAN FOR  
MORE INFO

Here at JTP we are widely regarded as the go-to timber window specialists for local contractors and developers alike. Providing impartial and unbiased advice when it comes to replacement vs refurbishment.

We bring our manufacturing and refurbishment teams together to ensure a cost-effective service is delivered for every project, on time and on budget.



As a company we are SMAS accredited and have external H&S consultants on hand to assist with all manner of H&S requirements. All of our site based operatives hold the relevant CSCS cards and up to date health and safety training certificates. Our supervisors hold SSSTS or SMSTS qualifications and are time served allowing them to ensure the smooth running of your project no matter it's size or complexity.



# WARRANTY

*This product warranty covers items detailed below:*

*This warranty stands as long as 6 monthly checks are carried out to paint work, hardware and the general function of all windows and doors. Please record these checks and any items to note in the maintenance record within the back of this guide or another suitable location.*

## Wood frame & sash:

The Company warrants that all JTP installed wood components are free from defects in workmanship and materials that could affect performance for a period of 10 years. To achieve this desired service please follow the after-care procedure.

## Ironmongery & seals:

The Company warrants locks and hinge systems for a period of 10 years. Handles and ironmongery will be covered by the manufacturers warranty, this will vary dependant on product chosen. Surface finishes for ironmongery are not covered by this Warranty. Weather seals are warranted for a period of 25 years.

## Double glazed units & glass:

The Company warrants that the glass will comply with the Glass and Glazing Federation's visual quality standards.

The Company warrants that seals on double glazed units will be free from failure (failure is taken to mean failure of the insulated glass unit resulting in penetration of moisture into the air space and appearance of moisture on the glass inside the airspace) for a period of 10 years from delivery. If the failure occurs in the first three years, the Company will be responsible for the supply and fitting of replacement glass units. If failure occurs after this but before 10 years, then the Company's obligations are limited to supplying the unit only.

The Company reserves the right to supply a whole sash as an alternative to supplying glass for re-glazing on site. No other glass defect or phenomena are covered by this Warranty.

## Surface treatment:

The Company warrants that the standard three coats opaque finished joinery is warranted for up to 7 years and the stain finishes up to 5 years against blistering or flaking but excluding natural resin exudation and movement around knots. Regular maintenance should be carried out as specified in the operation and maintenance manuals. Consideration should be given to the effect extreme climates can make on the lifespan of surface coating. Please refer to the Climate Guideline chart.

## Climate Charts:

This Warranty covers the coatings against:

- Peeling.
- Cracking (over greater than 5% of the coated area).
- Damage resulting from fungal growth within the coating but this should be cleaned in the 6 monthly maintenance programs.
- Significant 'yellowing' of the coating.
- Premature erosion of the film leading to areas of exposed timber.

It does not guarantee against:

- The exudation of resin.
- Extractive staining around knots.

General wear or loss of shine within the colour

CLIMATE GUIDE CHART			
	MODERATE	HARSH	EXTREME
	Typically, non-coastal areas at low altitude	Exposed inland locations and areas within 0.5 miles of the coast	Areas of high altitude and exposed coastal sites
<b>SHELTERED:</b> e.g. Beneath porch or large roof overhang	<b>10 YEARS:</b> For opaque coatings, 5 years for translucent coatings	<b>8 YEARS:</b> For opaque coatings, 5 years for translucent coatings	<b>7 YEARS:</b> For opaque coatings, 4 years for translucent coatings
<b>PARTLY SHELTERED:</b> e.g. Windows built back in reveal	<b>8 YEARS:</b> For opaque coatings, 5 years for translucent coatings	<b>7 YEARS:</b> For opaque coatings, 4 years for translucent coatings	<b>6 YEARS:</b> For opaque coatings, 2-3* years for translucent coatings
<b>NOT SHELTERED:</b> e.g. Face of building	<b>7 YEARS:</b> For opaque coatings, 4 years for translucent coatings	<b>6 YEARS:</b> For opaque coatings, 2-3* years for translucent coatings	<b>5 YEARS:</b> For opaque coatings, 2* years for translucent coatings
<i>*2 years for light shades e.g. Pine and Light Oak</i>			

## Exclusions to this Warranty:

- Damage to the surface coating has occurred by physical damage, for example damage caused by window cleaner's ladders, damage to cill extension joints by handling or installation, pet damage, chemical damage, damage caused by bad maintenance or poor design of building.
- Where damage has occurred as a result of faulty installation, repairs, alterations, work processes or pollution from surrounding areas.
- Where damage has occurred from excessive cleaning processes or hosing down of product.
- Where products have been stored in an unventilated area prior to fitting or areas that have been unventilated during the construction processes.
- Where products have been used in swimming pool areas without correct paint coating. Special paint required.
- Where damage that is caused by external causes outside the control of the Company which shall include, accident, fire, disaster, burglary.
- Where products have been exposed to unusual physical conditions.
- Where surface wear has been caused by natural elements.
- Where cill projections exceed 85mm. Paint supplier will not warranty the coating over this size.
- Where any sums remain due to the Company.

Provided always all surface treatment warranties are subject to environmental conditions as stated in our coatings information to ensure that the product has been maintained in accordance with the Company's Warranty conditions.

## Claims procedure:

In the unlikely event you believe you have a valid claim please contact JTP Joinery and speak to customer services.

## Validation:

It is necessary for the customer to substantiate the date of delivery and provide proof of purchase.



---

**01803 666316**

[info@jtpjoinery.co.uk](mailto:info@jtpjoinery.co.uk)

[www.jtpjoinery.co.uk](http://www.jtpjoinery.co.uk)

**JTP Joinery Limited**

Unit 3, Aller Vale Buildings, Moor Park Road,  
Kingskerswell, Newton Abbot, Devon TQ12 5AZ